



KAMAZ

TECHNOLOGIES OF THE CHAMPIONS



KAMAZ-5490 (4x2)

- Powerful 428 HP, EURO-5 Engine
- Comfortable Sleeper Cab with Two Bunks
- State-of-the-Art Electronic Systems (EBS, ESP, ECAS)
- Life Cycle of the Truck is 1 000 000 km

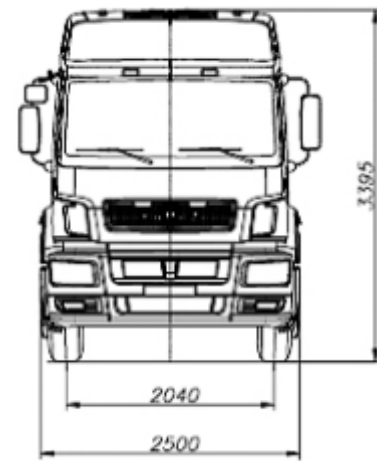
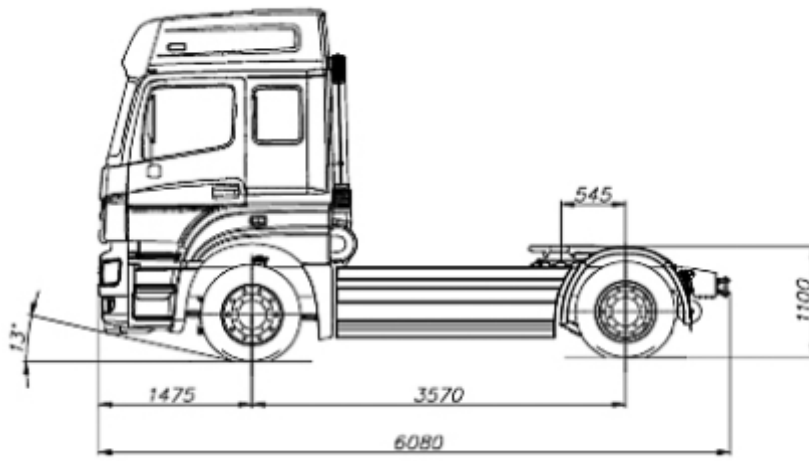

KAMAZ-5490 (4x2)

Specifications

Weight Parameters and Loads:

Curb Weight, kg, no more than.....	7900
- Front Axle Load, kg.....	5300
- Rear Axle Load, kg.....	2600
Technically Permissible Load on the Fifth Wheel, kg.....	10550
Technically Permissible Maximum GVW, kg.....	18600
- Front Axle Load, kg.....	7100
- Rear Axle Load, kg.....	11500
Technically Permissible Maximum Weight of the Towable Semi-Trailer, kg.....	36100
Technically Permissible Maximum GCW, kg.....	44000

Engine:

Model.....	Mercedes-Benz OM 457LA (Euro 5)
Type – Diesel, Turbo-Charged, Charge Air Intercooling	
Maximum Effective Horsepower, kw (HP).....	315 (428)
at Crankshaft RPM, min-1.....	1900+50
Maximum Effective Torque, N-m (kgf-m).....	2100 (220)
at Crankshaft RPM, min-1.....	1100+50
Number of Cylinders and Cylinder Arrangement.....	6, inline
Displacement, Liters.....	11.97

Fuel System:

Fuel Tank Capacity, Liters.....	2x400
---------------------------------	-------

Electrics:

Voltage, Volts.....	24
Batteries, V/Ahr.....	2x12/190
Alternator, V/wt.....	28/2000

Clutch:

Type.....	Diaphragm, Single Plate
Drive.....	Hydraulic with Pneumatic Booster

Transmission:

Model.....	ZF 12AS 2131
Type.....	Mechanical
Non-Synchro-Mesh, Twelve Speed	
Control.....	Automated

Transmission Ratios on Gears:

	1	2	3	4	5	6	Reverse
	15.86	9.56	5.87	3.47	2.09	1.28	14.68
	12.33	7.44	4.56	2.70	1.63	1.00	11.41

Final Drive:

Type.....	Hypoid
Transmission Ratio.....	3.077

Brakes:

Drive Type.....	Electric Pneumatic
Front Brakes.....	Disk Type
Rear Brakes.....	Disk Type

Wheels and Tyres:

Wheel Type.....	Disk
Tyre Type.....	Pneumatic, Tubeless
Rim Size.....	9.00-22.5
Tyre Size.....	315/60 R22.5

Cab:

Type.....	Cab-over-Engine
Configuration.....	Sleeper Cab with Two Bunks

GVW Truck Specifications:

Maximum Speed, No Less Than, km/hr.....	110
Negotiable Gradient, No Less Than, %.....	18
External Overall Turning Radius, m.....	8.5

KAMAZ

8-800-555-00-99

www.kamaz.ru, callcentre@kamaz.org



* in Russia